

Alternative syntheses of methylated sugars. XVIII.*

Synthesis of methyl 2,4-di-*O*-acetyl- β -D-xylopyranoside

P. KOVÁČ and J. ALFÖLDI

*Institute of Chemistry, Slovak Academy of Sciences,
809 33 Bratislava*

Received 27 November 1978

Methyl 2,4-di-*O*-acetyl-3-*O*-benzyl- β -D-xylopyranoside (*II*), from which the title glycoside *IV* can be obtained in a virtually quantitative yield, has been obtained *via* two independent routes. In the first procedure, 3-*O*-benzyl-D-xylose was acetylated with acetic anhydride in pyridine under controlled conditions to give 85% of crystalline 1,2,4-tri-*O*-acetyl-3-*O*-benzyl- α,β -D-xylopyranose (*I*). Treatment of *I* with hydrogen bromide in dichloromethane gave the corresponding glycosyl halide and *II* was obtained by condensation of the halide with methanol in the presence of mercuric cyanide. The alternative procedure for the preparation of *II* comprises opening of the anhydro ring in methyl 2,3-anhydro- β -D-ribofuranoside with benzylalcoholate anion in benzyl alcohol and conventional acetylation of the formed methyl 3-*O*-benzyl- β -D-xylopyranoside (*III*).

Метил-2,4-ди-*O*-ацетил-3-*O*-бензил- β -D-ксилопиранозид (*II*), из которого получается в заглавии указанный гликозид *IV* практически с количественным выходом был приготовлен двумя независимыми путями. Первый из них исходит из 3-*O*-бензил-D-ксилозы, из которой ацетилированием ацетангидридом в пиридине при контролируемых условиях получается кристаллическая 1,2,4-три-*O*-ацетил-3-*O*-бензил- α,β -D-ксилопираноза (*I*) с 85%-ным выходом. Ацетаты *I* были превращены под действием бромистого водорода в дихлорметане в соответствующий гликозилгалид, из которого получен *II* конденсацией с метанолом в присутствии цианистой ртути. Другим возможным путем получения *II* является раскрытие эпоксидного кольца в метил-2,3-ангидро- β -D-рибопиранозиде анионом бензилалкоголята в бензиловом спирте и ацетилирование образующегося метил-3-*O*-бензил- β -D-ксилопиранозид (*III*).

Unambiguous synthesis of positionally isomeric methyl β -xylobiosides required a series of methyl di-*O*-acetyl- β -D-xylopyranosides. Owing to comparable reactivity of the hydroxyl groups in D-xylose, dimolar acetylation of methyl

* Part XVII: *Collect. Czech. Chem. Commun.* **44**, 928 (1979).

β -D-xylopyranoside yields a complicated mixture of partially acetylated derivatives. Since the isolation of individual products from such mixtures is difficult methyl 2,3- and 3,4-di-*O*-acetyl- β -D-xylopyranosides were synthesized [1, 2] from suitable precursors not requiring partial acetylation. The present work describes the synthesis of methyl 2,4-di-*O*-acetyl- β -D-xylopyranoside (IV), the last hitherto unknown member in the series of di-*O*-acetates of methyl β -D-xylopyranoside, based on the same principle.

To obtain the title substance two independent routes were tried. The starting point in the first procedure (Scheme 1, A) was 3-*O*-benzyl-D-xylose obtainable [3] in 6 steps from D-glucose. In analogy with the observation of others [4] according to which acid-catalyzed reaction of D-xylose or its 3-*O*-methyl derivative with methanol gives at the equilibrium mainly the corresponding methyl α -glycoside, treatment of 3-*O*-benzyl-D-xylose with methanolic hydrogen chloride yielded crystalline methyl 3-*O*-benzyl- α -D-xylopyranoside [3]. Since the isolation of the corresponding methyl β -glycopyranoside from the mother liquor, containing in addition to the two pyranosides also the two furanosides, would require separation of a complicated mixture by chromatography, methyl 3-*O*-benzyl- β -D-xylopyranoside was prepared from 3-*O*-benzyl-D-xylose via its per-*O*-acetate and the corresponding glycosyl halide.

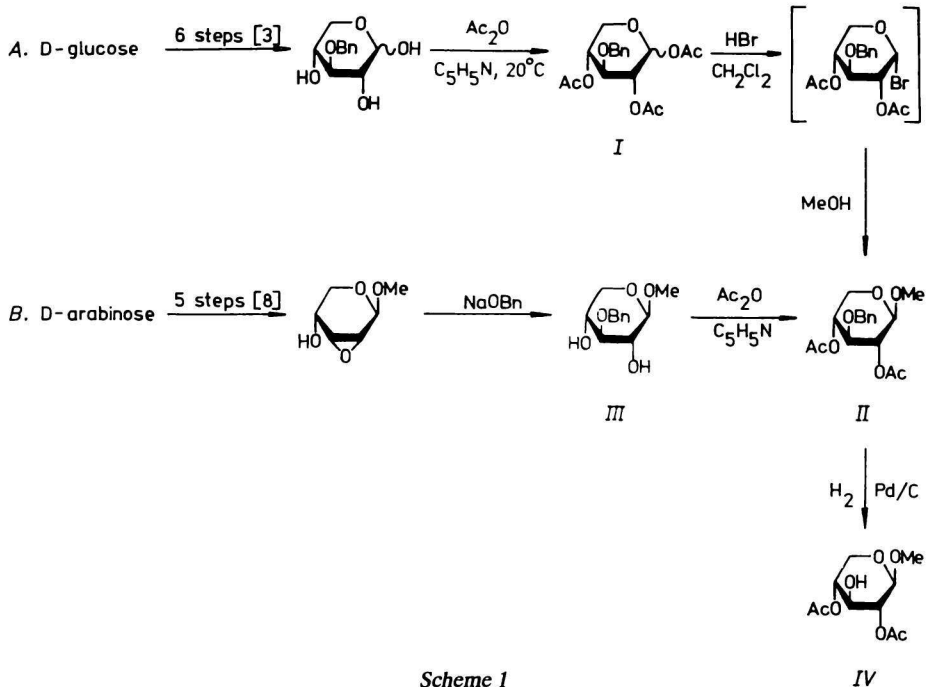

Scheme 1

We have previously shown [1] that the ratio of pyranoses to furanoses in the reaction mixture of acetylation of 2-*O*-benzyl-*D*-xylose depends largely upon the reaction conditions. When 3-*O*-benzyl-*D*-xylose was acetylated applying conditions [1] under which the least amount of furanoses was formed from 2-*O*-benzyl-*D*-xylose a mixture of crystalline acetates *I* was isolated in 85.5% yield. The p.m.r. spectrum of the crude acetylation product did not reveal the presence of furanose structures. It showed, *inter alia*, two doublets for H-1 at δ 5.75 and 6.22 ($J_{1,2} = 5.5$ and 3.5 Hz) the intensities of which corresponded to the presence of the two anomeric acetates in an approximate ratio of $\alpha:\beta = 1:0.85$. The isolated crystalline product had the specific optical rotation more negative ($[\alpha]_D = +12.3^\circ$) than had the crude product ($[\alpha]_D = +18.2^\circ$). Considering the ratio of the acetates present in the crude product, as shown by p.m.r. spectrometry, the high yield of the crystalline material isolated from it suggested that an anomerically pure material was not obtained by crystallization. This was confirmed by p.m.r. spectrum of *I* showing two doublets for H-1 with δ and $J_{1,2}$ values identical to those observed for H-1 signals present in the spectrum of the crude product. The altered intensity of the H-1 signals showed that the crystalline material was enriched in the β -anomer, the individual acetates being present in an approximate ratio of $\alpha:\beta = 1:1$.

Extensive debenzylation was observed [5] during attempts to convert *I* to the corresponding glycosyl halide under the conditions described for the preparation of 2,4,6-tri-*O*-acetyl-3-*O*-benzyl- α -*D*-glucopyranosyl bromide [6] from 1,2,4,6-tetra-*O*-acetyl-3-*O*-benzyl-*D*-glucose, *i.e.* by treatment of the latter with hydrogen bromide in glacial acetic acid. When *I* was treated with hydrogen bromide in dichloromethane a glycosyl halide was formed which, when reacted with methanol in acetonitrile in the presence of mercuric cyanide, gave methyl 2,4-di-*O*-acetyl-3-*O*-benzyl- β -*D*-xylopyranoside (*II*) in 61% yield. The cleavage of the benzyl group in *II* by catalytic hydrogenolysis then afforded the wanted, crystalline di-*O*-acetate *IV*. The location of acetyl groups in *IV* was confirmed by its p.m.r. spectrum showing chemical shifts of H-1—H-4 ring protons (Table 1) in agreement with the substituents at C-1—C-4.

Nucleophilic opening of the anhydro ring in alkyl 2,3-anhydro- β -*D*-ribosides has been extensively studied. It has been concluded [7] that the reaction proceeds *via* an attack of the nucleophile predominantly at C-3 resulting in the formation of the corresponding derivative of *D*-xylose. Accordingly, in the second approach to the synthesis of *IV* (Scheme 1, *B*), the readily accessible [8] methyl 2,3-anhydro- β -*D*-ribopyranoside was used as the starting material. Its reaction with benzylalcoholate anion in benzyl alcohol afforded methyl 3-*O*-benzyl- β -*D*-xylopyranoside (*III*) in 65% yield. Subsequent acetylation gave a diacetate identical in all respects with *II* obtained following the procedure *A* (Scheme 1). The β -*D*-xylo configuration of *III* follows also from the coupling constants for the ring protons observed in its p.m.r. spectrum (Table 1).

Table 1

Chemical shifts and coupling constants for I—IV

Compound	Chemical shifts ^a (δ)											Coupling constants (Hz)					
	H-1	H-2	H-3	H-4	H-5	H-5'	CH ₂	Ph	Me	OH	Ac	J _{1,2}	J _{2,3}	J _{3,4}	J _{4,5}	J _{4,5'}	J _{5,5'}
I ^b	5.75 d	5.03 q	3.73 t	c	4.18 q	3.49 q	4.73 s	7.30 s	—	—	2.01—2.15 ^d	5.5	7.5	8.0	4.5	7.0	12
II	4.36 d	4.94 q	3.66 t	4.85 ^f	4.12 q	3.31 q	4.65 s	7.30 s	3.45 s	—	2.05 ^e	6.0	7.5	7.5	4.5	7.0	12
III	4.15 d	3.40 q	3.23 q	3.63 o ^g	3.93 q	3.09 q	4.69 d	7.31 s	3.47 s	2.73 d ^o	—	6.5	7.0	8.5	4.5	6.5	10.5
IV	4.46 d	4.80 q	3.73 t	4.81 ^f	4.13 q	3.41 q	4.91 d	—	3.46 s	3.03 d ^o	2.18 ^e	5.5	7.0	7.0	4.5	7.0	12

a) Peak multiplicities: s — singlet, d — doublet, t — triplet, q — quartet, o — octet.

b) Anomeric mixture: unless stated otherwise, the data given refer to the β -acetate.

c) Partially overlapped with H-2 signals of both anomers.

d) Signals for O-acetyl protons of both anomers.

e) Six-proton singlet.

f) Partially overlapped.

g) Disappears on deuteration.

Experimental

Melting points were determined on a Kofler hot-stage. Optical rotations were measured with a Perkin—Elmer automatic polarimeter, Model 141. The p.m.r. spectra (80 MHz) were obtained for solutions in chloroform-d (internal standard tetramethylsilane) using Tesla BS 485 B spectrometer. Proton-signal assignments were made by the Indor technique.

Thin-layer chromatography (t.l.c.) on Silica gel G and preparative chromatography on columns of dry-packed silica gel was performed with benzene—acetone mixtures: A. 4:1, B. 10:1, C. 15:1. Before packing the silica gel was equilibrated with 40% (v/w) of the mobile phase. Detection was effected by charring with sulfuric acid (5%, v/v) in ethanol.

The solution of hydrogen bromide in dichloromethane (0.08 g/ml), used in the conversion of per-*O*-acetyl-3-*O*-benzyl- α,β -D-xylopyranose to the corresponding glycosyl halide was prepared as described previously [1]. Unless stated otherwise, the solutions were concentrated at 40°C/2 kPa.

1,2,4-Tri-O-acetyl-3-O-benzyl- α,β -D-xylopyranose (I)

Acetic anhydride (15 ml) was added portionwise at 0°C to a solution of 3-*O*-benzyl-D-xylose (5 g) in dry pyridine (15 ml) and the mixture was left at 0°C for 15 min, and then at 20°C for 1 h. The product, isolated in the usual manner, was a syrup (7.5 g, $[\alpha]_D^{22} = +18.2^\circ$ (c 1.36, chloroform)) which crystallized on standing. Crystallization from ethanol gave chromatographically pure material (6.52 g, R_f 0.6, solvent C) and a further crop of crystalline material (1.1 g, total yield of crystalline substance 85.5%) was obtained after trituration of the concentrated mother liquor with isopropyl ether. Recrystallization of a portion gave the analytical sample melting at 74—76°C and having $[\alpha]_D^{22} = +12.3^\circ$ (c 1.22, chloroform).

For $C_{18}H_{22}O_8$ (366.36) calculated: 59.00% C, 6.05% H; found: 58.86% C, 6.16% H.

Methyl 2,4-di-O-acetyl-3-O-benzyl- β -D-xylopyranoside (II)

a) Compound I (0.5 g, 1.36 mmol) was dissolved in dichloromethane (3.3 ml) and after addition of hydrogen bromide in dichloromethane (4.2 ml) the mixture was left at room temperature and with the exclusion of atmospheric moisture for 30 min. After concentration (30°C), the solution of the residue in a minimum amount of acetonitrile was added to a mixture of acetonitrile (15 ml), methanol (60 μ l, 1.48 mmol), and mercuric cyanide (190 mg, 0.75 mmol), and the reaction mixture was stirred for 15 min. T.l.c. (solvent B) then showed the absence of the starting bromide (R_f 0.8) and the presence of a major product (R_f 0.5). Small amounts of other components (R_f 0.2, 0.25, 0.6, and 0.65), not further examined, were also present. The mixture was concentrated, the residue extracted with chloroform and the chloroform solution was washed with aqueous 1 M potassium bromide solution and water, dried with anhydrous sodium sulfate and concentrated. Crystallization from ethanol gave 165 mg of II, and a further amount of the same material (117 mg, total yield 61.3%) was obtained by chromatography of the material that remained

in the mother liquor. After recrystallization, compound *II* showed m.p. 95.5–96°C and $[\alpha]_D^{22} = -57^\circ$ (*c* 1, chloroform).

For $C_{17}H_{22}O_7$ (338.25) calculated: 60.34% C, 6.55% H; found: 60.41% C, 6.54% H.

b) Acetic anhydride (7.5 ml) was added to a solution of *III* (4.5 g) in dry pyridine (10 ml) and after 3 h at room temperature t.l.c. (solvent *B*) showed that the reaction was complete. Methanol (5 ml) was added to destroy the excess of the acetylation reagent and the solution was concentrated after 30 min. Crystallization from ethanol gave a product (5.50 g, 92%) which was in all respects identical with the above described material.

Methyl 3-O-benzyl-β-D-xylopyranoside (III)

A solution of methyl 2,3-anhydro-β-D-ribose (5 g) in freshly prepared 1 M sodium benzoxide in benzyl alcohol (100 ml) was heated at 70–80°C with the exclusion of atmospheric moisture and carbon dioxide for 6 h. T.l.c. (solvent *A*) of a portion of the reaction mixture (~0.2 ml, worked up as described below, except for the means of the removal of benzyl alcohol which was done by concentrating the deionized solution with several additions of water at 70°C) then showed complete disappearance of the starting material (*R_f* 0.4) and the presence of *III* (*R_f* 0.3) as the major product. The mixture was cooled (20°C), diluted with ethanol (100 ml) and deionized with Dowex 50 W (*H⁺* form) resin. The solution was concentrated and benzyl alcohol was removed at 110°C (bath)/133 Pa to give a dark residue. Colourless, chromatographically pure *III* (3 g) was obtained by crystallization from chloroform–isopropyl ether and washing the crystals once successively with ether–isopropyl ether 1:1 and 1:2. The material in the mother liquor was chromatographed to give a further crop of *III* (2.7 g, total yield 65.5%). Recrystallization of a portion afforded the analytical sample melting at 103–104°C and having $[\alpha]_D^{22} = -71.5^\circ$ (*c* 1, chloroform).

For $C_{13}H_{18}O_5$ (254.27) calculated: 61.40% C, 7.13% H; found: 61.34% C, 7.17% H.

Methyl 2,4-di-O-acetyl-β-D-xylopyranoside (IV)

Compound *II* (5 g) in ethanol–acetone (1:1, 150 ml) was hydrogenated over 5% palladium-on-charcoal catalyst (0.5 g) at room temperature until t.l.c. showed complete disappearance of the starting material. The mixture was filtered and the filtrate concentrated to give a chromatographically homogeneous syrup (3.6 g, ~100%, *R_f* 0.2, solvent *B*) which crystallized on standing. After two recrystallizations from ethyl acetate–isopropyl ether compound *IV* showed m.p. 61–64°C and $[\alpha]_D^{22} = -71.7^\circ$ (*c* 1, chloroform). These physical constants did not change on further recrystallization.

For $C_{10}H_{16}O_7$ (248.23) calculated: 48.38% C, 6.50% H; found: 48.25% C, 6.48% H.

Acknowledgements. The authors thank K. Paule for the microanalyses and G. Košícký for optical rotation measurements.

References

1. Kováč, P. and Palovčík, R., *Chem. Zvesti* **31**, 98 (1977).
2. Kováč, P. and Alföldi, J., *Chem. Zvesti* **32**, 519 (1978).
3. Kováč, P. and Hirsch, J., *Chem. Zvesti* **27**, 668 (1973).
4. Bishop, C. T. and Cooper, F. P., *Can. J. Chem.* **40**, 224 (1962).
5. Kováč, P., unpublished results.
6. Finnan, P. A. and Warren, C. D., *J. Chem. Soc.* **1962**, 3089.
7. Guthrie, R. D., in *The Carbohydrates*, Vol. IA, p. 451. (Pigman, W. and Horton, D., Editors.) Academic Press, New York, 1972.
8. Hough, L. and Jones, J. K. N., *J. Chem. Soc.* **1952**, 4349

Translated by P. Kováč